

RESERVE COPY

PATENT SPECIFICATION

626,208



Convention Date (United States of America): May 24, 1944.

Application Date (in United Kingdom): Nov. 9, 1945.

No. 29898/45.

Complete Specification Accepted: July 12, 1949.

Under Rule 17A of the Patents Rules 1939-47, the proviso to Section 91(4) of the Patents & Designs Acts, 1907 to 1946 became operative on July 21, 1947.

Index at acceptance:—Classes 4, S: 8(ii), F1; 38(iv), R(2a1: 36a); 46, A(2b: 3); 55(ii), O1x; 64(ii), T1; 64(iii), F(2: 3b); and 68(i), K1.

COMPLETE SPECIFICATION

Recovery and Utilization of Water in Aircraft

I, HARRY ALFRED MULVANY, a Citizen of the United States of America, of 2342, Ashby Avenue, Berkeley, State of California, United States of America, do hereby declare the nature of this invention and in what manner the same is to be performed, to be particularly described and ascertained in and by the following statement:—

10 This invention relates to the recovery and utilization of water on aircraft and it can be applied to any aircraft that produces waste gases from the operation of its propelling apparatus, or from any of its auxiliary apparatus.

15 More specifically, the invention is addressed to the problem of water supply on transport aircraft including controls for the apparatus and involves also a method and apparatus for treating waste gases or exhaust gases from aircraft apparatus, operable while the aircraft is in flight to recover at least a portion of their water content, and to treat and process the recovered water so that it will be suitable for the many uses incidental to aircraft travel.

20 The procedure I employ involves the cooling of the gases of combustion to produce a water condensate. This condensate water contains toxic ingredients including lead and ammonia, and its acidity is high, which of course renders it unfit for the uses of potable water. In accordance with the invention I may eliminate these objectionable characteristics by my treatment of the gas before the condensation, or from the water of condensation containing the impurities carried in the gas.

25 Aircraft transports employed in long non-stop flights find it necessary to carry a considerable quantity of water for cooking, washing, and as drinking water, etc. In present practice on larger type transport airplanes as much as forty gallons must be carried and even this quantity is found to be inadequate.

[Price 2/-]

It is most desirable to condition the air in the cabins of passenger craft in long flights at high altitudes, and this involves the introduction of moisture into the cabin air; but the quantity of water that would be necessary to do this is so great that it is impracticable for the aircraft to carry sufficient water for this purpose.

50 It is also a fact that the horse-power of internal combustion engines on aircraft may be increased approximately 20% by injecting moisture into the intake manifold. This can be accomplished for short periods without damage to the engine, and has the advantage of increasing the mileage while cooling the engine.

55 In view of the many demands for water on a modern transport aircraft, outlined above, the carrying of a sufficient water supply has become a serious problem, as, of course, the dead load on the aircraft must be held down to a minimum.

60 One of the objects of the present invention is to provide simple means for recovering the water carried in the waste gases from engines carried by the craft, and for purifying it, so that it is potable and usable for the various purposes outlined above.

65 Aircraft operate under widely varying conditions as to atmospheric temperatures and flying elevations both of which variables affect the performance of such apparatus. Hence one of the objects of this invention is to provide general controls for the apparatus that will operate satisfactorily under all conditions to insure an adequate water supply, while at the same time effecting a saving in weight carried by the craft. More specifically stated, it is one of the objects to utilize the slipstream of atmospheric air to effect the condensation of the waste gases, and to provide adequate controls for preventing injury to the condenser or freezing of the condensate water due to abnormally low temperature of the slipstream; also to pre-

Price 5s. 0d.

Price 25p

Price 4s. 0d.

BEST AVAILABLE COPY

vent overheating of the condenser during the warming up of the engine or engines.

In the practice of the invention a portion of the exhaust gases is diverted from the engine exhaust for condensing, and one of the objects of the invention is to provide simple means for automatically regulating the quantity of gas diverted into the condenser, controlled by the conditions existing at the condenser.

Another object of the invention is to provide simple means for automatically regulating the quantity of slipstream air passing through the condenser in accordance with the existing conditions at the condenser; also to provide controls that will function to prevent ice forming within the condenser.

One of the objects of the invention is to provide means for removing the toxic ingredients from the recovered water condensate which will combine a minimum of weight with the maximum of purifying function in producing potable water; also to eliminate its acidity.

Further objects of the invention will appear hereinafter.

The invention consists in the apparatus, and in the method described hereinafter the features of which contribute to produce an effective method and apparatus for the recovery and utilization of water in an aircraft.

A preferred embodiment of the invention is described in the following specification while the broad scope of the invention is pointed out in the appended claims:—

In the accompanying drawings which are for illustrative purposes;

Fig. 1 is a diagrammatic view illustrating the elements of the apparatus and showing the controlling means, certain parts being broken away.

Fig. 2 is also a diagrammatic view and illustrating a method and means for practicing the invention in which the toxic ingredients are removed from the gases before they are cooled sufficiently to condense the moisture carried by them; this view also illustrates a portion of the separator for separating the water condensate from the gases, including means for filtering the water.

Fig. 3 is a view upon an enlarged scale illustrating more fully the means shown in Fig. 2 for removing the toxic ingredients from the gases.

Fig. 4 is a chart illustrating the exit gas temperatures and the condensation rate in pounds per hour plotted against varying altitudes.

Fig. 5 is a perspective illustrating the apparatus including the condenser, its gas intake, and its out-take from the con-

denser; and also showing the intake for the atmospheric air from the slipstream. This view also illustrates the separator that takes the gases from the condenser and separates the water condensate from the remaining gas; and the control for the gas outlet from the separator. This view is broken away to illustrate a preferred point of application of a thermostatic device which I employ to prevent the condenser from acquiring too low a temperature.

Fig. 6 is a vertical section taken in a front and rear plane illustrating how the apparatus shown in Fig. 5 can be applied, if desired, within the leading edge of a wing to facilitate taking air from the slipstream.

Fig. 7 is a diagrammatic view illustrating a portion of the gas intake that conducts the gas into the condenser and illustrating an automatic control for a valve in this intake to set the same in accordance with the speed of air flow through air intake and the condenser, and illustrating the electrical apparatus that is automatically controlled to close the circuit through a motor for swinging the valve toward or from its closed position.

Fig. 8 is also a diagrammatic view illustrating one of a set of dampers or louvers that control the admission of atmospheric air from the slipstream through the intake of the condenser, and illustrating electrical apparatus for controlling the same automatically to set the louvers in a regulated position depending upon the temperature of that part of the condenser where the thermostatic device is applied. In this view the intermediate or middle louver is illustrated in dotted lines with the rack broken away that connects it to the other louvers located within the air intake for operating them in unison.

Fig. 9 is a fragmentary vertical section in a front and rear direction taken through the air intake and illustrating the louvers in their open position in full lines.

Fig. 10 is a diagrammatic view and includes a side elevation of the mechanism of a thermostat device that is applied to the gas out-take from the condenser, and including a portion of the outlet pipe for carrying the gases away from the separator. This view illustrates the electric circuits for effecting the automatic control of a valve located in this gas outlet pipe, from this thermostatic device.

Fig. 11 is a vertical section taken about in the plane of the line 11—11 indicated in Fig. 10.

Fig. 12 is a view showing curves; indicating the average gas temperature after going through the successive passes that guide the gas through the condenser, and

another curve showing the average tube wall temperature in the different passes. The abscissas indicate distance along the heater tubes in feet and the vertical ordinates indicate temperatures in Fahrenheit degrees.

In practicing the invention, as shown in Fig. 1, 1 indicates an exhaust pipe for gases of combustion coming from an internal combustion propelling means for an aircraft, or from an auxiliary engine employed for any purpose.

These hot gases may come from an internal combustion engine of any known type or from a rocket-type propelling apparatus such as is now coming into use. A portion of the gas flowing along this outlet pipe 1 is diverted to an apparatus for removing the toxic ingredients either from the gas while still in its gaseous state, or from condensate water produced by cooling the gases directly in a condenser 2. This is accomplished by passing the gas through a duct preferably in the form of coils 3 including a series of passes 4. This condenser is indicated diagrammatically in Fig. 1 but is shown in detail in Fig. 5. It has a forwardly projecting intake 5 that connects to an inlet mouth 6 (see Fig. 6) that may be located in the leading edge of a wing 7. However, this location for the air inlet or the intake is not essential, and it may be located at any point on the aircraft such as in a nacelle or in any other location where a portion of the slipstream of atmospheric air will naturally flow into the intake 5 when the aircraft is in flight.

The interior of the casing 8 of the condenser 2 operates as a duct for conducting the atmospheric air past the coils 3.

As the proper functioning of the condenser depends largely upon the relative proportions of the hot gases passing into the coils 3 and the cooling current of atmospheric air passing into the intake 5, I provide automatic means for controlling the flow of the diverted hot gas through the gas pipe 9. This is accomplished through the medium of a valve 10 that is controlled automatically by a pressure-actuated means or device 11 located inside the intake or condenser body and which is actuated by the changes of internal pressure or lateral pressure exerted by the air current flowing through the condenser. There is, of course, considerable changing in this pressure, due to changes in speed of the aircraft, and to the fact that there is considerable resistance to flow of the air current through the condenser and around the coils 4. This pressure sensitive device or "pressure-stat" 11 is illustrated more in detail in Fig. 7 and will be described more fully hereinafter. This device

includes a diaphragm 12 which is exposed to the pressure of the flowing current of air, and if this pressure rises to a certain point, for example, to a pressure corresponding to five inches of a water column, the diaphragm will move so as to close an electric circuit 13 including electro-mechanical means 14 which will operate the valve 10 to move it toward an open position proportionately to the rises in the pressure exerted against the diaphragm 12.

In Fig. 7 14 indicates a motor diagrammatically. This is preferably a shunt-wound motor the shaft 15 of which operates through a worm 16 to drive a worm-wheel 17 which operates through reduction gears including a pinion 18 and a large gear 19, to drive a flexible shaft 20 that connects to the shaft 21 of the valve 10 which as indicated is of the "butterfly" type.

In Fig. 5 this pressure-sensitive device is illustrated mounted on the side wall 22 of the intake 5. However, in Fig. 7, which is a diagrammatic view, this device is illustrated as though located on the opposite wall of the intake so that the pressure upon the diaphragm 12 would be exerted upon its right side as illustrated in Fig. 7. When this diaphragm is moved by rising pressure, a stem 23 connected to the diaphragm will move toward the left and compress a light return spring 24, and in this movement a lateral projecting contact finger 25 carried by the stem will engage a fixed contact 26 which closes a circuit from the conductor 27 to the finger 25, and thence through the conductor 28 that is connected to the fixed contact 26. This conductor 28 at its other end is connected to a fixed contact 29 which cooperates with a movable contact lever 30 pivotally mounted at 31 and normally pulled by a spring 32 into engagement with the fixed contact 29. However, this switch composed of the contacts 29 and 30 is a limit switch and will be opened automatically through the agency of a lug 33 projecting out from the periphery of the gear wheel 19, which will engage the end of the lever 30 and push it toward the left, thereby opening the circuit through the motor 14. This will operate to effect a closing movement of the valve 10 to a nearly closed position. As illustrated in Fig. 7 however this lug 33 is shown in contact with the end of a pivoted switch lever 34 which cooperates with a fixed contact 35 so as to operate as a limit switch for the opening movement of the butterfly valve 10. In other words, as illustrated in Fig. 7, the contacts 34 and 35 can cooperate to maintain a temporary circuit through a conductor 36 that connects this

lever 34 with a contact 37 that corresponds to the fixed contact 26 already described, but which is closed by a movement of the diaphragm 12 which would be due to a reduction in pressure within the air intake 5.

The circuits through the motor 14 are controlled by two solenoids 38 and 39 the former of which is connected to a conductor 40 connected to the contact 31 and is connected by conductor 41 to a main circuit wire 42, the other main circuit wire 43 has the conductor 27 already referred to, connected to it.

The fixed contact 35 and the coil 39 are connected to a conductor 44 that connects to the main conductor or wire 42.

There are two 4-point switches 45 and 46 which in Fig. 7 are shown in their open position. Either of these switches may be closed without closing the other and when one is closed a mechanical interlocking connection 47 of any suitable form prevents the other switch from being closed.

These interlocking preventers for performing this function are standard devices and consequently need not be described in detail. When the solenoid coil 38 is energized it pulls all four of the connected switch levers 48 toward the right as viewed in Fig. 7, to connect the live conductors 49 and 50 to the field coils 51 of the motor, and to the armature of the motor through the commutator 52; the circuit through the field coils 51 is established through the wires 53, and 54 that connect with wires 55 and 56 respectively leading into and from the coils 51. The circuit through the armature is established through wires 57 and 58 connecting to conductors 59 and 60.

When the solenoid coil 39 is energized the four contact levers 61 connect up the live wires 62 and 63 to the armature circuit wires 59 and 60 and also to the field coils 55 and 56, the direction of flow of the current being such that the motor will run in reverse direction from that when the switch 46 is closed. A hand operated switch 64 may be provided for connecting up to a source of electro-motive force supplied through conductors 65 and 66.

In addition to controlling the quantity of gases of combustion diverted from the exhaust pipe 1, I provide means for controlling the out-flow of the gases that have been separated from the condensate water while they are leaving the separator 67. This separator as illustrated in Fig. 5 is a centrifugal type of separator into which the gases are delivered from the condenser out-take or separator intake 68. In Fig. 5 this is illustrated as a flat form of flue the side walls 69 of which converge toward the point of connection through

the side wall of the centrifugal separator 67, so that the gases flow tangentially into the separator, and circulate around within the same in the general manner indicated by the dotted arrows in Fig. 5. By reason of the centrifugal action, the water carried with the gases will be thrown against the circumferential wall of the separator and will pass down through a filter 70 in which is maintained a filter bed 71 of a substance capable of removing the toxic ingredients carried in the condensate water. This water collects in the bottom of the casing of the filter 70 and can be drawn off by opening the small valve 72 in its outlet connection 73 leading off from the filter bottom.

The gas outlet pipe 74 leads out through the cover of the centrifugal device and its inlet mouth, indicated in dotted lines at 75, is located at a considerable distance below the cover so that the circulating gases pass down to a lower level before they finally pass up through the outlet. As illustrated, the upper part of the outlet pipe 74 has a goose-neck so as to present a horizontal extension 76, and in this extension a valve 77 is provided for regulating the effective area of flow of the gas passing the valve. The degree of opening of this valve is regulated through the agency of a thermostat device 78 which is preferably applied so that it takes its temperature from that of the gases passing through the separator intake 68, a wire cable or connection 79 being provided leading over to the valve controlled mechanism 80 that is associated with the valve 77.

This valve controlled mechanism 80 and the thermostat device 78 are illustrated more in detail in Fig. 10. The thermostat device 78 is constructed so that it will open or close the vane 81 of this butterfly valve in stages. Any suitable thermostat device may be employed for this purpose that will function to control the valve 81 so that it is operated in this way. In the present instance as illustrated in Fig. 10, the thermostat device includes two "Invar" (Registered Trade Mark) bars or equivalent elements 82 the ends of which are connected to a base-plate 83 secured to the side wall 69 of the intake 68. The bars 82, as illustrated, are bowed outwardly away from each other and when the base plate 83 expands or extends itself by increase of temperature of the gases the bars 82 will assume a more flattened arc, that is to say, they will approach each other. Between the two bars 82 and supported on a fulcrum bracket 84 a contact lever 85 is supported. This lever is attached to a lever head 86 carrying a pivot pin 87 that connects the

70

75

80

85

90

95

100

105

110

115

120

125

130

lever head to the supporting bracket 84. A coil spring 88 between the bar 82 that carries the fulcrum bracket 84, and the lever head 86, urges the contact lever 85 downwardly as viewed in Fig. 10 and holds it against an adjustable stop 89. This adjustable stop is carried on the opposite bar 82. By adjusting a calibrated wheel 90 the stop 89 can be adjusted in or out in its threaded bearing 91 to alter the position of the tip of this stop screw 89, thereby enabling the position of the free end of the lever 85 to be adjusted with respect to the insulated contacts 92 mounted on an insulated plate 93.

The free end of the lever 85 carries an insulating plate 94 in which relatively movable contacts 95 are carried. These contacts are mounted on shanks 96 that are freely movable through guide openings in the insulating plate 94, and the upper ends are pressed downwardly by coil springs 97 that also function to carry current to them from a lead-wire 98. The distance between the forward ends of the relatively movable contacts 95 and the relatively fixed contacts 92 are graduated preferably as shown. Contact 95a that is located nearest to the pivot pin 87 of the lever has the shortest distance to move to close the circuit through it, and so on. With this arrangement as the lever 85 swings toward the contacts 92 evidently they will be engaged in succession by the cooperating relatively movable contacts 95 so as to close circuits through the circuit wires 99, 100 and 101 in succession. These wires connect respectively to corresponding solenoid coils 102, 103 and 104 which function in succession but at different moments, to advance a core bar 105. The upper end of this core-bar is formed into a rack 106 meshing with a pinion 107 attached to a trunnion 108 of the butterfly valve 81.

The upper end of the rack 106 is guided to slide through a lug 109, and beyond the lug its end is engaged by means to return this bar and hold the butterfly valve normally in open position. In the present instance the upper end of the rack 106 thrusts against the lever 110 pivotally supported at 111. The end of this lever carries a spring 112 that is attached to a fixed eye-bolt 113. Anti-friction ball 114 may be provided between the end of the rack 106 and the side of the lever 110 to reduce the friction entailed in this movement.

The core bar 105 carries three solenoid cores 115, 116 and 117 respectively, which are located in graduated positions with respect to the lower ends of their corresponding coils, with the lowest core 115 located further up into its corresponding coil 102 than the other cores. With this

organization of parts it will be evident that when the circuit is closed first through the wire 99 the core 115 will be pulled up a short distance into the coil 102. When the circuit is closed in the wire 100 the core 116 will be pulled up a further distance into its coil 103; and likewise as to the core 117 and its coil 104. This will effect movement of the butterfly valve 81 toward its closed position in three stages as described.

Of course as the circuits are opened at the contacts 92 the spring 112 will return the butterfly valve 81 step-by-step to its wide open position as shown in Fig. 10. In this open position a collar or collars 118 on the core-bar 105 or on the rack 118 may seat against a rest indicated at the horizontal lines 119. Only one of these collars is necessary.

In order to enable the base plate 83 to quickly acquire the approximate temperature of the hot gases flowing through the gas duct 120 (see Fig. 11) the inner face of this base plate 83 is provided with a plurality of projections or fins 121 that extend into the interior of this flue. They may extend through an opening 122 formed in the side wall 69.

The control mechanism illustrated in Figs. 10 and 11 will operate to close the butterfly valve 81 more or less, according to the temperature of the gases flowing through the flue 120 of the intake 69. That is to say if these gases have an abnormally high temperature the butterfly valve 81 will assume its most nearly closed position thereby reducing the flow of the gas into and through the separator 67.

In the operation of this apparatus when flying through an atmosphere of abnormally low temperature there is danger of the slipstream air current that passes through the air intake 22, cooling the condenser 2 sufficiently to cause freezing of moisture within it. In order to overcome this difficulty I provide another control operating automatically to reduce the flow of slipstream air through the intake 5 if the temperature of the condenser becomes dangerously low. The apparatus for this purpose includes a thermostatic device 123 (see Fig. 5) that is preferably attached to a guiding wall for the exhaust gases that pass through the condenser, and preferably at a point at or near where those gases find exit from the condenser, because this is the point where the lowest temperature will naturally exist in the condenser.

This thermostatic device 123 and its associated control apparatus is illustrated in Fig. 8. In a condenser such as illustrated which would have a series of passes such as the passes 4 illustrated in Fig. 1 through which the gases pass in succes-

sion, the thermostatic device 123 would be attached to one of the tubes of the last pass. That is to say at or near the point where the gases were finding exit from a condenser. In Fig. 8 124 indicates such a tube, and the thermostatic device 123 would be attached to its outer side. In this Fig. 8 and in Fig. 9 I illustrate a louver type of valve involving a plurality of butterfly valves or separate louvers indicated generally by the numeral 125 in Fig. 9. All of these three louvers are moved in unison by any suitable means such as by means of a pinion 126 attached to the trunnion of each of these louvers, and all of which mesh with the teeth of a rack 127 that is movable up or down to close or open the louvers.

The switches controlled by the thermostatic device 123 would have substantially the same construction as that illustrated in Fig. 10 including three movable contacts 128, 129, and 130 cooperating with relatively fixed contacts 131, 132 and 133. The thermostatic device 123 is mounted so that as the temperature of the wall of the tube 124 drops to a certain degree the contact 130 will move down and engage the relatively fixed contact 133. This will close a circuit through a solenoid coil 134 that corresponds to the solenoid coil 102 shown in Fig. 10. This solenoid coil 134 is the lowest one of a series of three including upper coils 135 and 136 which coils correspond to coils 103 and 104 as shown in Fig. 10. These solenoid coils exert magnetic force upon cores not illustrated, but which are similar to the cores 115 attached to the core bar 105. In other words when the coil 134 is energized it will give a limited upward movement to the core bar 137 that extends up through all three of the coils. This core bar carries at its upper end a contact actuator head 138. Now when contacts 130 and 133 come together, current flows through the wire 139 from the main 140 and through the wire 141 to the coil 134, thence by a return wire 142 back to the other main conductor 143. As indicated, the coils 134, 135 and 136 are wired in parallel from the conductor 142 through a branch wire 144. When the contact actuator head 138 rises by successive steps due to the successive closing of the contacts 130, 132 and 131 the actuator head 138 will close any one of the three normally open switches 145 located on the right hand side as shown in Fig. 8. In the first step or stage of actuation of this actuator head 138 it will engage the end of the tail arm 146 of the switch lever of the lowest switch indicated by the numeral 145a and will close a circuit through the relatively fixed contact 147. When this occurs a circuit will be closed from the main wire 140 through wire 148, branch wire 149 and normally closed switch 150 through a wire 151 that leads up to the contact 147, and from this point through wire 152 over to a solenoid coil 153, completing its circuit through wires 153a and 180. This solenoid controls a 4-point switch 154 and this coil can close this 4-point switch 154 so as to establish a circuit through a motor armature 155 by way of wires 156, 157, and 158. At the same time another pair of levers of this 4-point switch 154 will close a circuit through the field coils 159 of this motor 160, through wires 161, 162 and 163, the latter of which connects to a branch wire 164 leading out through this switch. This will drive the motor in a direction to rotate the trunnion 165 of the middle louver 125a in an anti-clockwise direction as indicated by the arrow in Fig. 8. This trunnion 165 carries a duplex type fan shaped contact wiper 166 having two fan shaped wiper ends, or fans, 166a and 166b. In the present instance the motor shaft 167 carries a worm 168 that meshes with a worm wheel 169 rigid with the trunnion 165 for rotating the louver 125a.

When the contact wiper 166a engages the end of the lever 170 of the switch 150, already referred to, a cam notch 171 in its forward edge engages the end of this switch lever and swings it toward the right, after which the end of this lever rides along and dwells on the circumferential periphery of the wiper. This holds this switch open against the force of its spring that normally holds it in a closed position. Opening this switch, of course, opens the circuit through the coil 153, and when this occurs the spring 172 connected with the switch lever of the switch 154 will pull this switch into its open position and stop the motor. The switch 150 is one of three similar switches, the other two switches similar to it being indicated by the reference numerals 150a and 150b. After the louvers 125 have been moved to the first stage closing position as would occur when the contact head 138 closes the switch 145a, if the temperature at the controlling thermostatic device 123 falls further, then a circuit will be closed through the fixed contact 132 which is wired to the coil 135, just like the coil 134 is wired to the contact 133. This coil 135 will operate to pull the armature rod 137 further up and cause the head 138 to engage the tail arm of the intermediate switch 145b, and this will close the circuit through the switch 150a, through the wires 148 and the wires 152; and this will reclose the 4-point switch 154 just as it was closed before through the agency of 130

the switch 145a. This will drive the motor in the same direction as before and move the contact wiper 166 further along in its same direction of movement. When the wiper end or fan 166a engages the end of the lever of the switch 150a it will open this motor circuit and stop the motor. The louver 125a will now be in its intermediate position. If the temperature at the tube 124 drops still lower, then the circuit will be closed through the contact 131 which will close the circuit through the coil 136, and this will close the circuit again through coil 133 and close the motor switch 154 again as before. The motor will then move again in the same direction, causing the wiper fan 166a to advance and eventually open the motor circuit again by engagement with the lever of the switch 150b.

When the contact wiper 166 is in the position just mentioned, that is to say, when the fan 166a has wiped over all three of the switches 150, 150a and 150b they will all remain open and at the same time the opposite fan 166b will have wiped across and closed three other normally open switches indicated generally by the reference number 173. These switches 173 are wired up individually to three normally open switches indicated generally by the reference numeral 174, and these latter switches are arranged so that their tail levers 175 can be engaged by the left end of the actuator head 138. Assuming that the louver 125a has been advanced to its third stage position, it should be understood that in that position the contact head 138 will be in engagement with the actuating lever of the uppermost switch 145c of the switches 145.

Assuming that the temperature at the thermostatic device 123 commences to rise, then the circuit will be opened through the contact 131 and this will permit the return spring 137a of the armature rod 137 to pull the rod down as far as the energized coil 135 will permit. This will stop the rod 137 in a position to enable the left end of the actuator head 138 to engage the uppermost switch 174a of the switches 174, and this will close a circuit through a fixed contact 176 that cooperates with this uppermost switch. This will close a circuit from the main wire 140 down through wire 148, through the lever actuated switch 173a (which is now held closed by the fan 166b,) and thence up through wire 177 to fixed contact 176a; and thence by wire 178 over to coil 179, and from this coil on wire 180 over to the main wire 143. This will operate a 4-point switch 181 that is similar in construction to the switch 154 and will move this switch to its closed position thereby closing the motor circuit

through the commutator 155 by way of wire 158 already referred to, and wire 182, also closing the motor circuit through the field coils 159 through the wires 162 and 163 already referred to.

The fixed contacts 183 of these two 4-point switches are wired in parallel to wires 184 and 185 that are connected through a switch 186 to the main wires 140 and 143.

Closing the motor switch 181 as described, will of course, drive the motor in a reverse direction, that is to say, in a direction which will drive the switch wiper 166 in a clockwise direction as indicated by the dotted arrow in Fig. 8, and this rotation will continue until the right edge of the fan 166b passes out of contact with the switch 173a, whereupon this switch will be opened by its spring 187 and the motor will stop. However, the fan 166b will still be in contact with the lever of the switch 173b and if, and when, the temperature increases at the thermostat 123 the contact 129 will pull away from the contact 132 and this will de-energize the coil 135 and permit the rod 137 and the switch contact head 138 to drop down to its next position. That is to say as far as will be permitted by the lowest coil 134 which will still be energized.

If and when the temperature at the thermostat 123 rises still further, then the contacts 130 and 133 will separate which will de-energize the coil 134 and permit the rod 137 to drop down to the position in which it is illustrated in Fig. 8.

From the centrifugal separator 67 the condensate water passes down through a constantly maintained filter bed 188 (see Fig. 1). In practice this water may be passed up through the filter bed, but for the purpose of illustration it is shown passing down through the filter bed. This filter bed is carried in a container 189 the interior of which is provided with a helical blade 190 which causes the water to pass in a helix through the filter bed. In this way I greatly increase the length of the course that the water passes through in going through the filter.

At some point in its course, and preferably before the water passes through the filter bed which is of activated carbon, I cause the water to pass through a layer 191 of asbestos, or other material capable of removing the oils or oily constituents and also any solid matter that may be carried in the water. The outlet pipe 192 for leading the water off from the filter 189 may be provided with a branch pipe 193 and valve 194 from which the condensate water is lead over to a reservoir for use by the passengers of the plane and for cooking, or other purposes.

70

75

80

85

90

95

100

105

110

115

120

125

130

This pipe 192 extends down and is provided with a branch pipe 195 and valve 196 which can be opened when desired to admit a small quantity of water into the outlet 197 from a super-charging blower 198 that delivers into the air intake manifold 199 for the engine or other propelling means burning hydrocarbon fuel.

This invention can be practiced to advantage in conjunction with air conditioning apparatus that will now be described. In adapting this invention to air conditioning, beyond the branch 195 the pipe 192 has an extension 200 with an automatically controlled valve 201 that will permit water to pass when required into the delivery pipe 202 of a blower or compressor 203 that delivers air into the air conditioned cabin. This valve 201 may be controlled by a humidostat 204 mounted somewhere in the air conditioned cabin, to open the valve 201 when the conditions warrant, to introduce water into the delivery pipe 202. In the position indicated in Fig. 1 this valve 201 is shutting off flow to the blower 203 and is discharging into a pipe connection 205 that would lead to the same tank or reservoir to which the pipe 193 is connected, or to another reservoir if that is more expedient. The humidostat 204 controls an automatic switch 206 in an energized circuit 207 including a solenoid 208, and the core 209 of this solenoid is connected to the lever 210 of the valve 201.

It is not essential to the practice of this invention to condense the moisture from the waste gases before effecting the elimination of the toxic ingredients and the acid ingredients. In Fig. 2 I illustrate apparatus which operates to eliminate the toxic ingredients and acid ingredients from the gases before they are cooled sufficiently to precipitate the water condensate. However, in this instance, I prefer to cool the gases down considerably below the temperature that they have when they come from the engine, and for this purpose I employ a cooling coil 211 having a sufficient length to bring the temperature down to a proper temperature for filtering through a filter bed of activated carbon in a filter 212. From this point the gases pass through a cooling coil 213 which would be mounted in a condenser similar to that shown in Fig. 1 and having coils subjected to the cooling effect of a current of air from the passing slipstream; and this condenser 213 would deliver in a tangential direction into a centrifugal separator 214 similar to the separator 67.

The gas filter 212 may have the usual construction of any type of effective gas filter. In the present instance in Fig. 3 I

have illustrated it as comprising an inner compartment 215 into which the gas is admitted and this compartment has a wall 216 of fine screen material. This central compartment 215 is completely surrounded above and on the sides by a filter space containing activated carbon 217 which is retained in an outer container 218 having a wall of screen material. This arrangement enables the gas to pass through in all directions into an outside envelope or container 219 the outlet of which connects to the condenser 213.

As illustrated in Fig. 2, the water passing down from the separator 214 may be passed, if desired, through a filter 220, although under ordinary conditions this filter could be dispensed with.

In Fig. 4 I illustrate a chart showing a plotted curve 221 which indicates the condensation rate in pounds per hour, (ordinates) plotted against flying altitudes measured in a horizontal direction. This chart also shows a curve 222 that indicates the temperature of the exit gases plotted against altitudes.

In Fig. 12 I illustrate another chart with plotted curves 223 and 224 respectively indicating the average gas temperature in the cooling tubes of the condenser, and the average cooling tube wall temperature. This chart indicates these temperatures plotted against abscissas ranging from five feet of length of cooling tubes, to twenty feet. These two curves of course have very similar characteristics and while the temperature of the tube wall is approximately 800° at the point where the gases are admitted, the gas temperature will be approximately 1400°. These curves of course approach each other so that when the gas passes out of the condenser the adjacent tube wall has approximately its same temperature.

The filter bed referred to above, and which I maintain for removing the toxic and acid ingredients from the gases or from the condensate water, must have a physical structure such that its granules will present a maximum superficial area, and this material should have a fineness enabling it to pass through a No. 20 mesh screen and be retained by a No. 48 mesh screen. A satisfactory carbon for this purpose is an activated carbon made from nut shells, such as the shells of coconuts. An activated carbon that is satisfactory for this purpose and which is found to fulfill these requirements is obtainable on the market and is known commercially as "Colombia" brand, grade F. It is manufactured by the Carbide and Carbon Chemical Company of New York City.

In this connection it should be stated that I have found that the water condensate in practicing this method has a pH of approximately 3.5, and in order to render this water potable and useful for all purposes on board a transport aircraft it is necessary to reduce this to approxi-

mately a neutral condition, that is to say approximately $pH7$.

In the following table I indicate the characteristics of the water after filtering with this activated carbon as compared with the characteristics of the water condensate before filtration:—

	Water of Combustion Before Passing Over Activated Carbon.	After Passing Through Carbon Bed
15	Odor	Sharp aromatic
	Color	Dirty Green
	Taste	Bitter almonds
20	Turbidity	Fine carbon suspensions
	pH	3.4
	No	—
	NO_2	1 P.P.M.
	NH_3	333 P.P.M.
25	Organic nitrogen	1.2 P.P.M.
	Lead	20 P.P.M.
	Phenol	28.2 P.P.M.
	Cyanide	Negative

P.P.M. = Parts per 1,000,000

80 The above table gives an average of three samples of water, and in conducting the test two gallons of water condensate were passed through approximately 25 grams of activated carbon in a column of one half inch in diameter and sixteen inches long. The water was floated up through the activated carbon.

85 The apparatus and method described above can be used to furnish a heating medium to the de-icing apparatus of the aircraft. Means for accomplishing this is indicated in Fig. 6 in which 2a indicates the outlet of air that has passed through the condenser 2. This outlet 2a is illustrated as provided with a branch 2b, and at the junction point of this branch with the outlet 2a a spreader valve 2c of vane type may be employed. In Fig. 6 this spreader valve is indicated in dotted lines and in the position indicated it will deflect all of the hot air passing through the outlet 2a down into the branch 2b, which would have an extension 2d leading off to the de-icing apparatus.

55 With this apparatus described, and practicing the method, sufficient water for all purposes on an aircraft can be recovered from the exhaust gases from the engine or engines, at the same time accomplishing a very substantial saving in the weight of water that an aircraft would be obliged to carry to afford a water supply equivalent to that possible by practicing this invention. For example, it would require considerably over 300 pounds of water on a certain air conditioned cabin airplane now in construction for crossing the Atlantic, not including the weight of water that this plane would have to carry for other purposes. This apparatus if installed on such a plane would hardly

increase the weight of the plane by more than seventy-five pounds and this would afford a water supply of approximately fifty pounds per hour.

Having now particularly described and ascertained the nature of my said invention and in what manner the same is to be performed, I declare that what I claim is:—

1. Apparatus for recovering water from the exhaust gases of internal combustion means on an aircraft, comprising condenser means exposed to the slipstream air passing the aircraft for condensing condensable constituents, including water, of said exhaust gases, and regulating means controlled by the air pressure in the condenser means for regulating the amount of exhaust gases passing through said condenser means.

2. Apparatus according to claim 1, characterized by the condenser means having an air inlet exposed to said slipstream, and said regulating means being an electrically operated valve for controlling the flow of exhaust gases through the condenser means and pressure responsive electric switch means responsive to air pressure within the inlet of the condenser means controlling said valve.

3. An apparatus according to claim 1 or 2, including means responsive to the temperature of the exhaust gases in the condenser for varying the flow of air from the slipstream passing through said condenser.

4. An apparatus according to claim 3, characterized by said temperature responsive means comprising a valve controlling the flow of air through the condenser and a thermostatic switch for controlling said valve, said thermostatic switch being

- exposed responsive to the temperature of exhaust gases which pass through the condenser.
- 5 5. An apparatus according to any one of claims 1 to 4, including means responsive to the temperature of exhaust gases which have passed through the condenser means for varying the flow of said exhaust gases through said condenser.
 - 10 6. An apparatus according to any of claims 1 to 4, characterized by a separator for separating the water condensed from the hot gases received by the condenser, and means including a thermostat associated with the separator for controlling the effective area of the exhaust for the waste gases from the separator.
 - 15 7. An apparatus according to any one of claims 1 to 6, including means associated with said condenser means for maintaining the temperature of the condenser means and the condensate above the freezing point.
 - 20 8. Apparatus for recovering water from exhaust gases of internal combustion means on an aircraft, comprising, condenser means exposed to the atmospheric slipstream passing the aircraft, for condensing condensable constituents of said exhaust gases, including water, and means responsive to the temperature of exhaust gases passing through the condenser for regulating the quantity of air from the slipstream passing through said condenser.
 - 25 9. An apparatus according to claim 8, characterized by the temperature responsive means including a valve controlling the flow of atmospheric air through the condenser and a thermostatically controlled switch for controlling the valve.
 - 30 10. Apparatus for recovering water from the exhaust gases of internal combustion means on an aircraft comprising: condenser means exposed to the atmospheric slipstream of the aircraft for condensing condensable constituents of said exhaust gases, including water; separator means for separating the water condensed from the hot gases received from the condenser; and temperature responsive means associated with the separator for controlling the effective area of the exhaust for the waste gases from said separator.
 - 35 11. An apparatus according to claim 10, characterized by said temperature responsive means including a thermostatic switch associated with the separator and a valve controlled by said thermostatic switch for controlling the waste gases leaving said separator.
 - 40 12. An apparatus according to any of claims 1 to 11, including an outlet duct for conducting the air from the condenser for de-icing the aircraft.
 - 45 13. An apparatus according to any of claims 1 to 12, including means for delivering condensate to the intake manifold of the internal combustion means.
 - 50 14. Apparatus for recovering water from the exhaust gases of internal combustion means on an aircraft, comprising: condenser means exposed to the slipstream air passing the aircraft for condensing condensable constituents, including water, of said exhaust gases, regulating means for controlling the air passing through the condenser means; and an outlet duct for conducting the air from said condenser for de-icing the aircraft.
 - 55 15. Apparatus for recovering water from the exhaust gases of internal combustion means on an aircraft, comprising: condenser means exposed to the slipstream air passing the aircraft for condensing condensable constituents, including water, of said exhaust gases; regulating means for controlling the air passing through the condenser means; and a duct for conducting condensate to the engine intake manifold.
 - 60 16. A method of obtaining water from the exhaust gases of internal combustion means on an aircraft comprising passing said gases through a condenser; causing air from the slipstream passing the aircraft to flow through the condenser for cooling the gases in said condenser so as to condense water vapor in said gases, and regulating the quantity of the gases passed to the condenser proportionately to the speed of said slipstream air flowing through the condenser air intake.
 - 65 17. A method of obtaining water from the exhaust gases of internal combustion means on an aircraft comprising passing said gases through a condenser; causing air from the slipstream passing the aircraft to flow through the condenser for cooling the gases in said condenser so as to condense water vapor in said gases; and regulating the quantity of gases passed to the condenser in accordance with the air pressure in said condenser.
 - 70 18. A method according to either of claims 16 or 17, including controlling the flow of air through the condenser in accordance with the temperature of the exhaust gases in said condenser.
 - 75 19. A method according to any of claims 16 to 18, including controlling the flow of exhaust gases through the condenser in accordance with the temperature of said exhaust gases which have passed through said condenser.
 - 80 20. A method of obtaining water from the exhaust gases of internal combustion means on an aircraft comprising passing said gases through a condenser; causing air from the slipstream passing the air-

craft to flow through the condenser for cooling the gases in said condenser so as to condense water vapor in said gases; and regulating the quantity of air flowing through said condenser in accordance with the temperature of exhaust gases passing through said condenser.

10 21. A method according to any of claims 16 to 21, including passing the condensate through a separator and controlling the escape of waste gases from the separator in accordance with the tempera-

ture of the gases adjacent said separator.

22. A method according to any of claims 16 to 21, characterized by conducting air from the condenser outlet for de-icing the aircraft. 15

23. A method according to any of claims 16 to 22, characterized by delivering condensate to the intake manifold of the internal combustion means. 20

Dated this 9th day of November, 1945.
MARKS & CLERK.

Leamington Spa: Printed for His Majesty's Stationery Office by the Courier Press.—1949.
Published at The Patent Office, 25, Southampton Buildings, London, W.C.2, from which copies, price 2s. 0d. each (inland) 2s. 1d. (abroad) may be obtained.

[This Drawing is a reproduction of the Original on a reduced scale.]

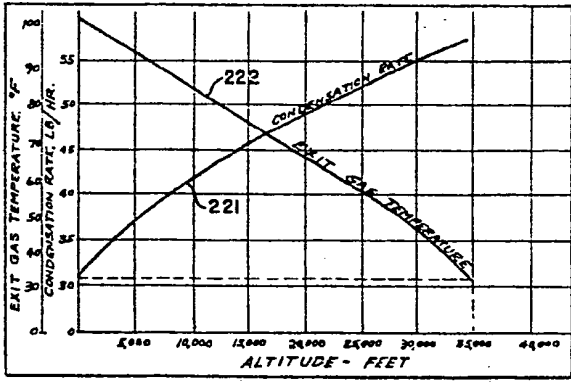
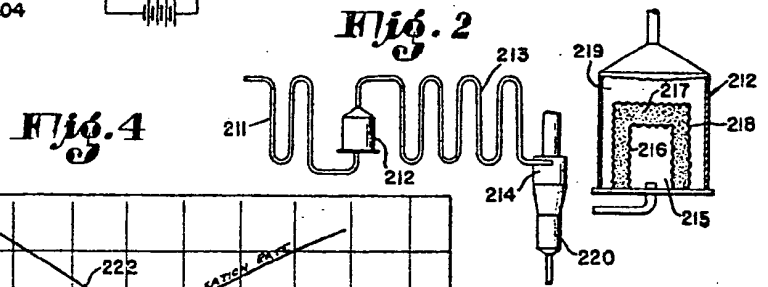
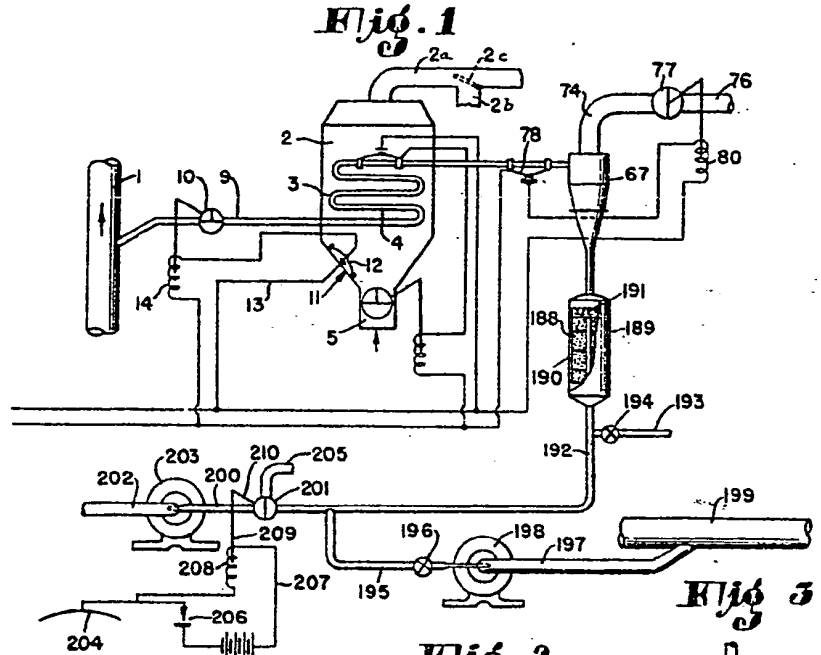
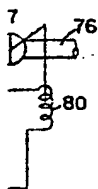
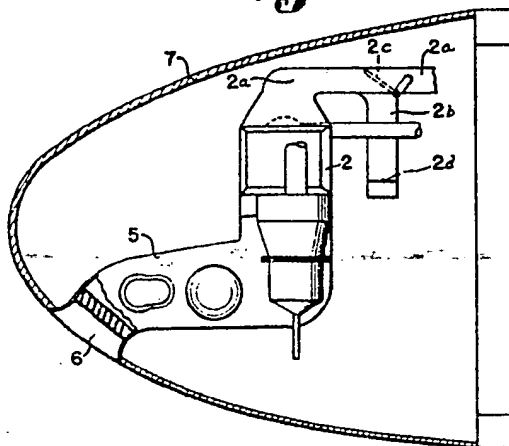

Fig 6



193

Fig. 5

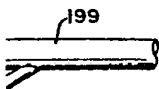
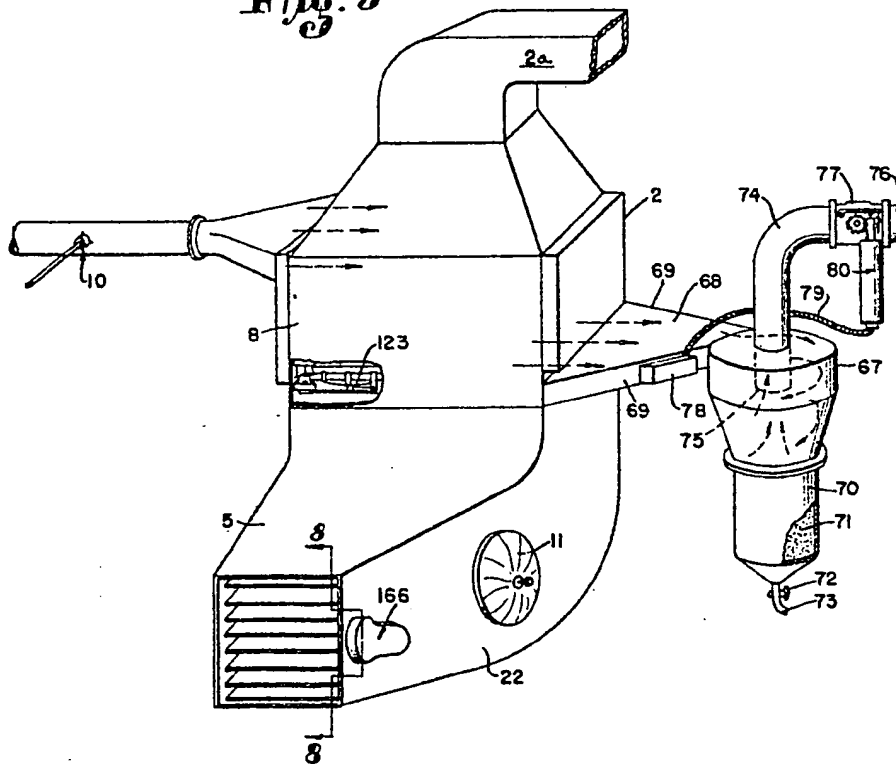
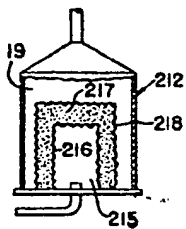

Fig 3



120

626208 COMPLETE SPECIFICATION

SHEET 1

4 SHEETS
SHEET 2

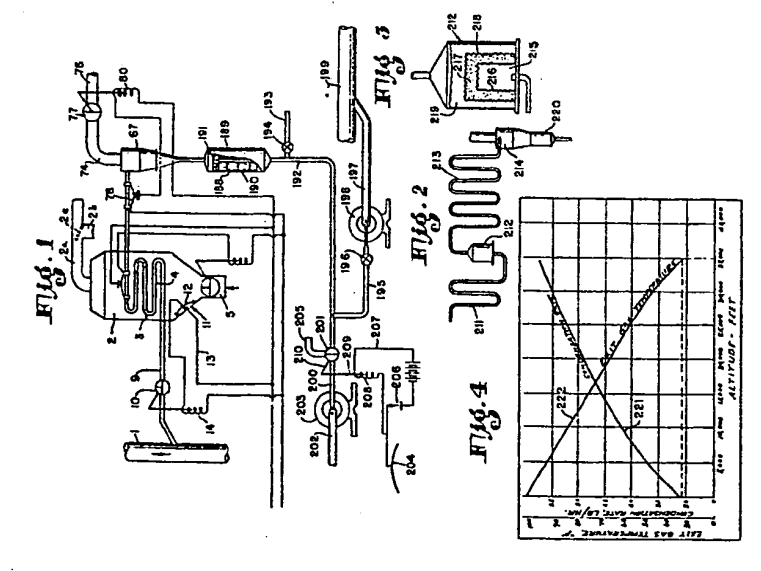
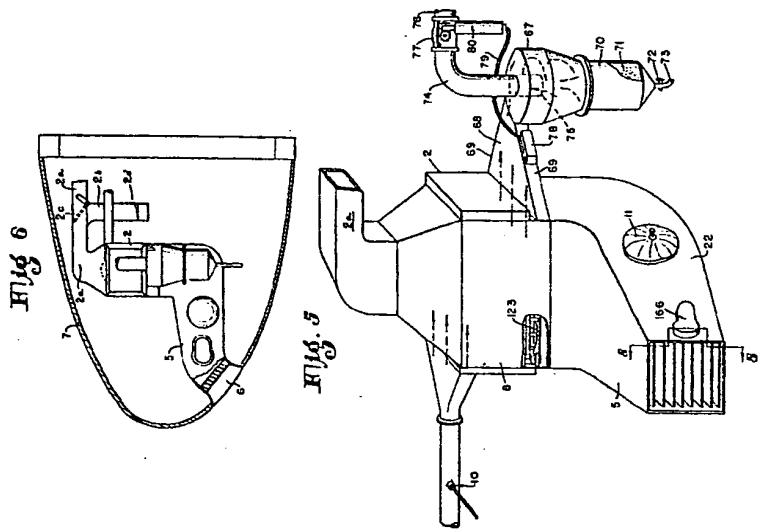

[This Drawing is a reproduction of the Original, on a reduced scale.]

H.M.S.O. (Type A)

[This Drawing is a reproduction of the Original on a reduced scale.]

Fig. 7

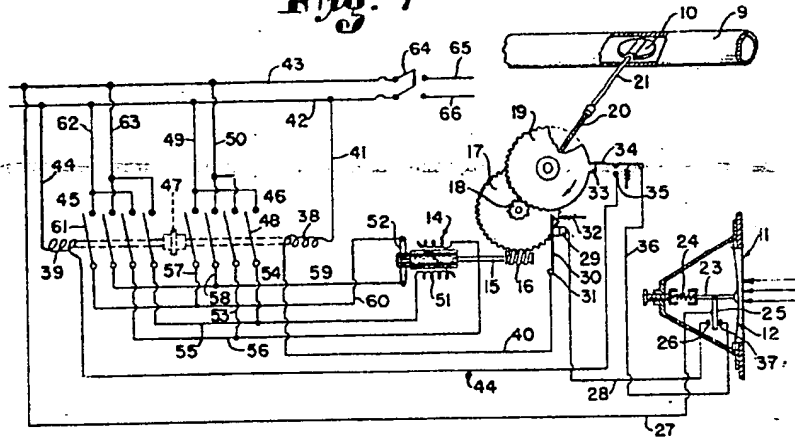
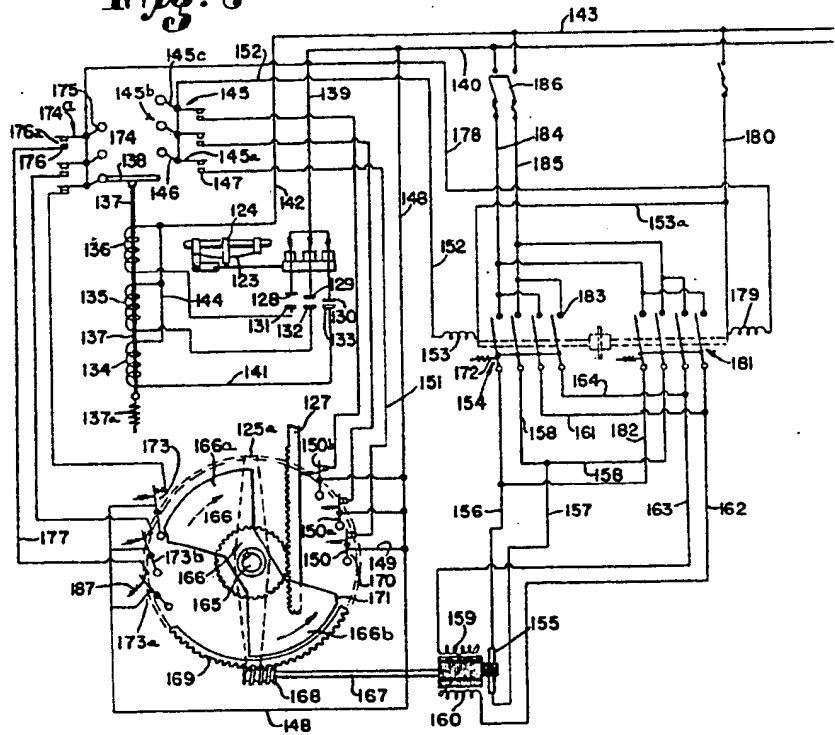
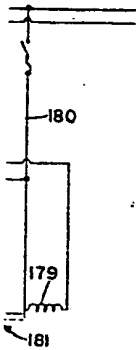
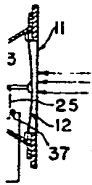

Fig. 8





-162

Fig. 9

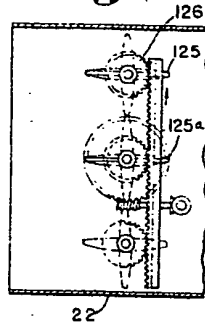

Fig. 12

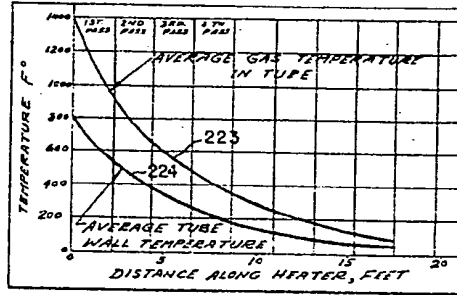

Fig. 10

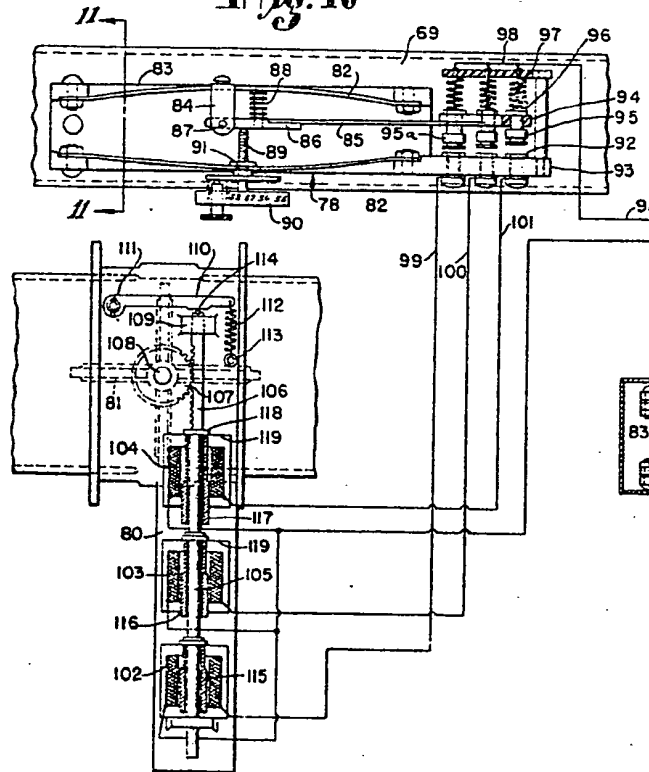
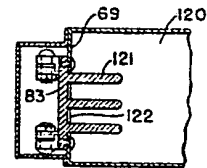

Fig. 11



THIS PAGE BLANK (USPTO)

**This Page is Inserted by IFW Indexing and Scanning
Operations and is not part of the Official Record**

BEST AVAILABLE IMAGES

Defective images within this document are accurate representations of the original documents submitted by the applicant.

Defects in the images include but are not limited to the items checked:

- BLACK BORDERS**
- IMAGE CUT OFF AT TOP, BOTTOM OR SIDES**
- FADED TEXT OR DRAWING**
- BLURRED OR ILLEGIBLE TEXT OR DRAWING**
- SKEWED/SLANTED IMAGES**
- COLOR OR BLACK AND WHITE PHOTOGRAPHS**
- GRAY SCALE DOCUMENTS**
- LINES OR MARKS ON ORIGINAL DOCUMENT**
- REFERENCE(S) OR EXHIBIT(S) SUBMITTED ARE POOR QUALITY**
- OTHER:** _____

IMAGES ARE BEST AVAILABLE COPY.

As rescanning these documents will not correct the image problems checked, please do not report these problems to the IFW Image Problem Mailbox.

(THIS PAGE BLANK (USPTO))